



CONCEPT ENGINEERING

World Class Design



SINCE 2002....

We Believe
in Quality

www.conceptenging.com

Mfrs & Exporter of :

**Screws Barrels & Screen Changer
for PLASTIC, RUBBER & FOOD
PROCESSING MACHINERY**

Company Profile

Located in Ahmedabad (Gujarat, India), we **“Concept Engineering”** are known as the most reputed manufacturer, exporter and supplier of high quality array of **Conical Twin Screw Barrel , Twin parallel screw barrel And Barrier Screw barrel, Extrusion Screw, Vented And Woven Screw Barrel, Ring Plunger Set, Single Screw Barrel Set, Grooved Feed Bush, Modular Screw Barrel, Injection Moulding Screw Barrel, Rubber Screw barrel, Food Screw barrel** and many more. At our infrastructural unit, the offered products are manufactured using high quality raw material and advanced technology as per the defined industry standards. Since our inception in 2002, we are supported by state-of-the-art infrastructural unit that is divided into various parts such as procuring, manufacturing, production, quality testing, R&D, sales & marketing and transport & logistics. Equipped with advanced tools and machinery, all these process are managed by our experts.

Being the most trusted organization supervised by our experts, we provide an enormous assortment of products. The offered products are known for their rust proof, anti corrosive, easy to install, dimensional accuracy, sturdiness and precisely designed. Our quality controllers ensure that all the offered products are checked on well defined quality parameters. Our team of professionals possesses rich experience and knowledge in the domain, which help us to cater to the requirements of the clients in the best possible way. These products are available in several specifications as per the specific needs of the clients. We appreciate the precious feedback of our customer in order to enhance our quality. Our transparent dealings, ethical business practices, easy payment option, timely delivery and quality conscious approach have made us the perfect option of our respected clients. Under the management of our Proprietor, **“Mr. Sohil Patel”**, we have achieved a highest position in the industry.

INTERNATIONAL ORGANIZATION FOR STANDARDIZATION

International Organization for Standardization

INFRASTRUCTURE

We are supported by an ultra-modern infrastructural facility that is furnished with all the modern tools and machinery that help us to manufacture the qualitative range of products. To ensure smooth production process, this infrastructure is categorized into different parts such as production, manufacturing, quality control, R&D, warehousing & packaging, etc. The equipped machines and tools are usually upgraded according to the current market changes. Apart from this, all our departments are supervised by our experienced technicians

TEAM

Backed by the support of our skilled professional, we have been able to provide a qualitative range of products. We have appointed dedicated and knowledgeable professionals that help us in providing premium quality products to our valuable clients. The professionals working with us are well-versed with the current improvements of the market and accordingly manufacture products to satisfy clients in the proper manner. In order to keep them updated with the latest market improvement, we organize important seminars, learning programs and workshops at regular basis.

WHY US

We have all in house facility like deep hole drilling machine, honing machine, gas nitrating furnace, CNC lathe machine, CNC thread milling machine, WMW milling machine, boring machine, radial drilling machine, special purpose screw policing machine and many more.

so, we serve best quality screw barrel in the world

Some of the distinguishing points that make us the best choice in the industry are as follows:

- Ethical business policies
- Ultra-modern infrastructural facility
- Best quality products
- Market leading price
- Efficient team of professional
- Wide distribution network

PARALLEL TWIN SCREW BARREL



TYPE - DOUBLE / TWIN

RANGE - ID 10 To 165 mm X LENGTH 400 To 4500 mm

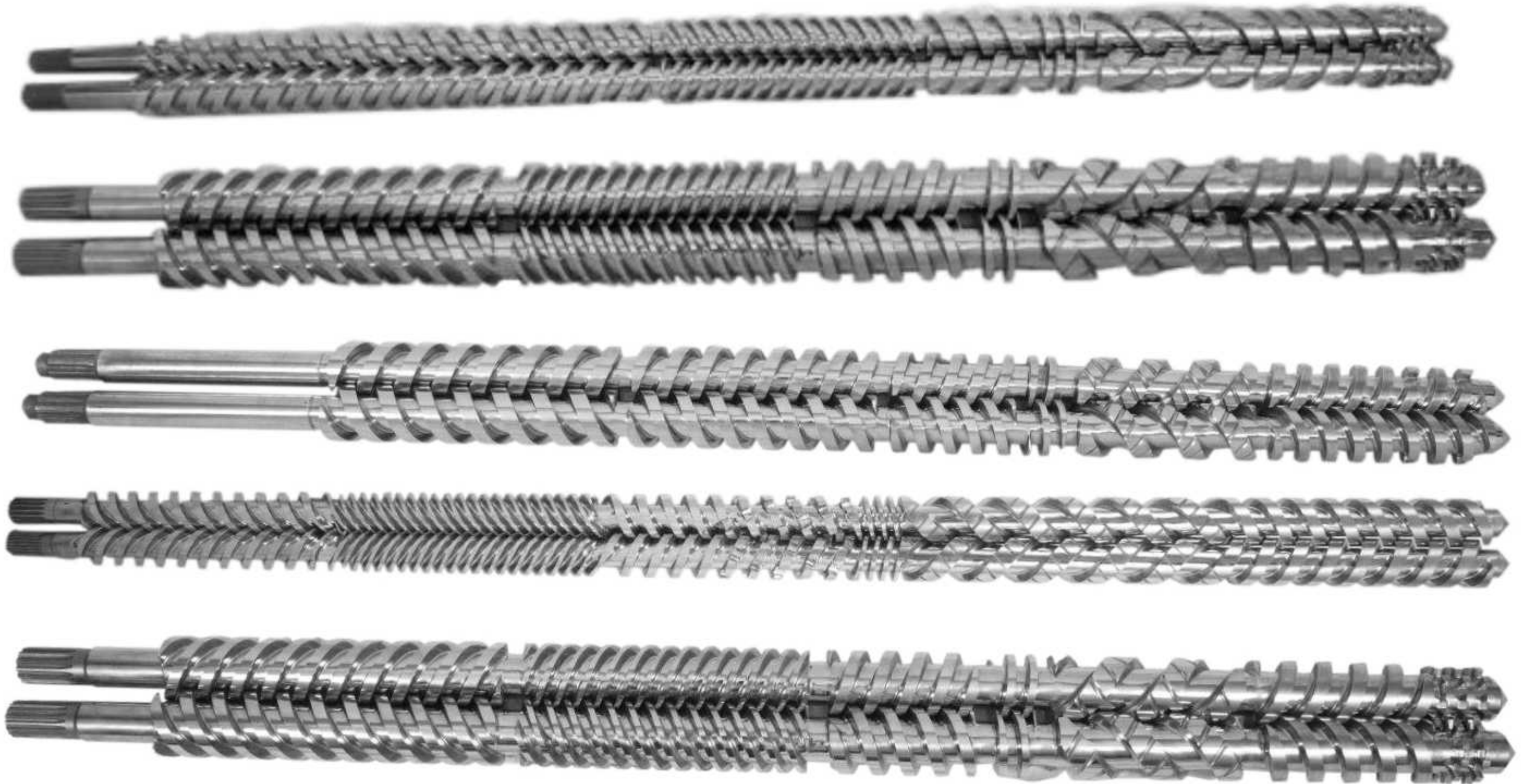

Twin Barrels



Front Barrel



EXTRUSION SCREW & BARREL



Grooves Sleeve



Extrusion Screw Barrel



Conical Screw barrel



Vented Screw Barrel

Bi-metallic SCREW Barrel

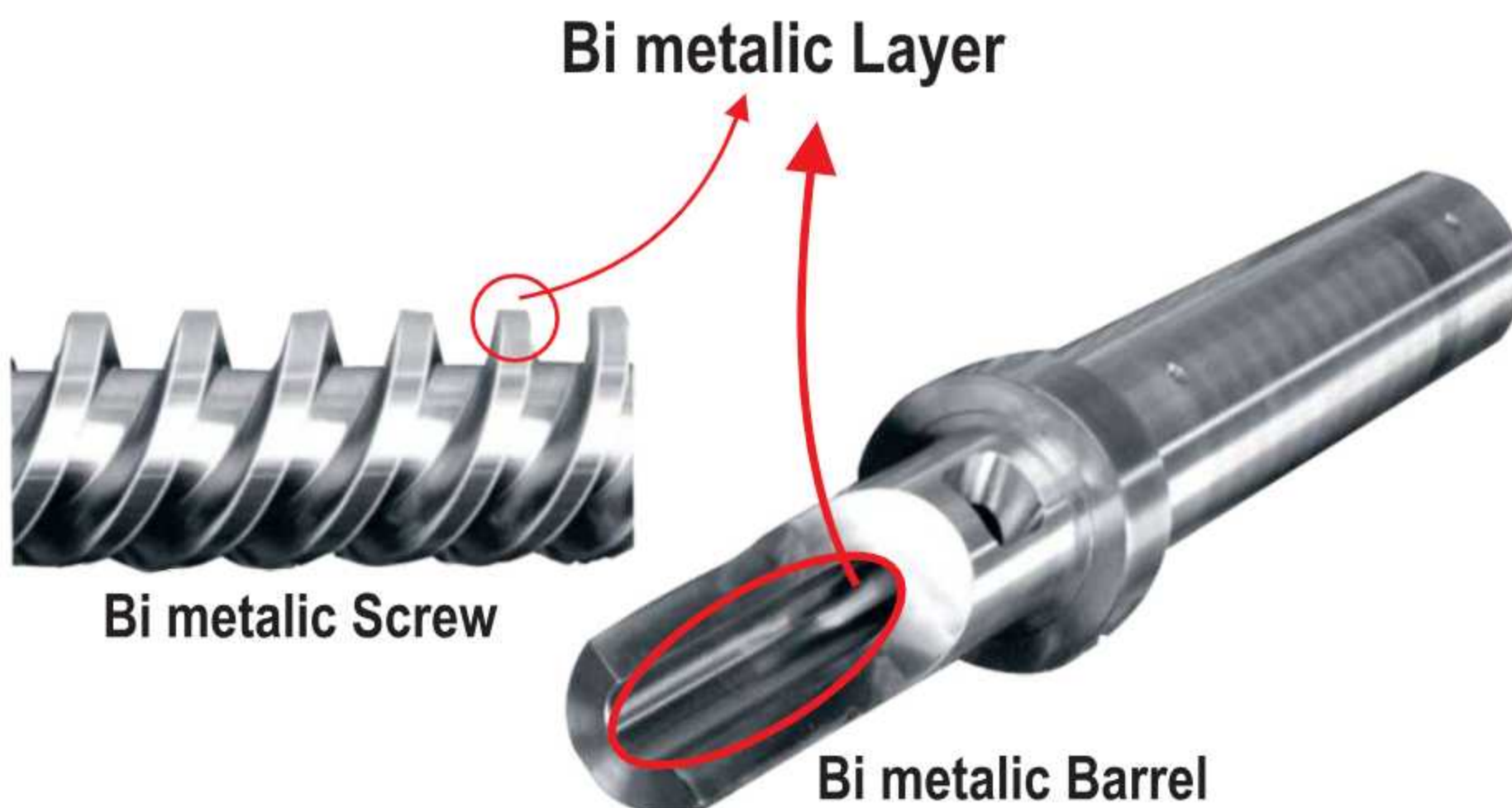

Bi metallic Layer

Bi metallic Screw

Bi metallic Barrel

PLATEN TYPE SCREEN CHANGER



Sr no.	Model	Output kg/hr	Mesh	Cartridge heater voltage (v)	Heating load (kw)	Hyd. power pack motor details (hp)
1	150	100-250	150	230/415	5.6	3
2	200	150-450	200	230/415	8.0	3
3	225	170-600	225	230/415	12.8	5
4	250	225-750	250	230/415	12.8	5
5	300	350-1000	300	230/415	24	7.5

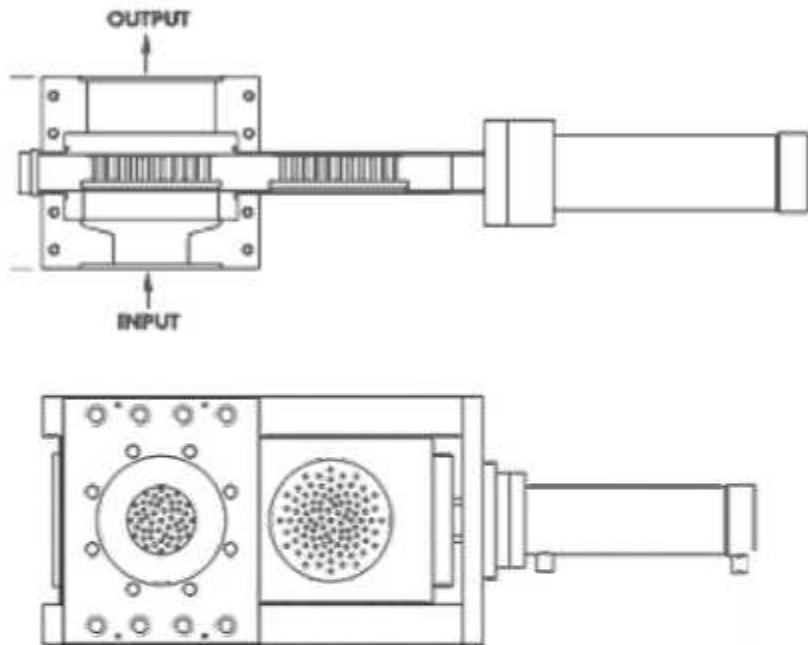

A range of typical applications

- Granule Reprocessing Plant
- Pipe plant
- Lamination Plant
- Sheet Plant
- MastBatch Planter
- Filler Plant
- Special Design for PVC Plant
- Special Design for Nylon Plant
- Lumps Plant (Gulla Plant)
- Blow Moulding Plant

Your benefits

- Filter remove the impurities and prevent the damages of Die.
- Filter improves the quality of final product.
- It is Hydraulic operated so plant output will we increased compare to manual operating. So, save the time and power with same output.
- Eliminate the idle time and easy to operate.
- Special arrangement given in breaker plate so, increase the mesh life and save money.
- Easy maintenance.

PLUNGER TYPE MANUAL SCREEN CHANGER



Sr no.	Model	Output kg/hr	Mesh	Cartridge heater voltage (v)	Heating load (kw)
1	80	140-225	80	230/415	1.6
2	90	160-250	90	230/415	3.2
3	100	200-350	100	230/415	4.0
4	110	200-375	110	230/415	4.8

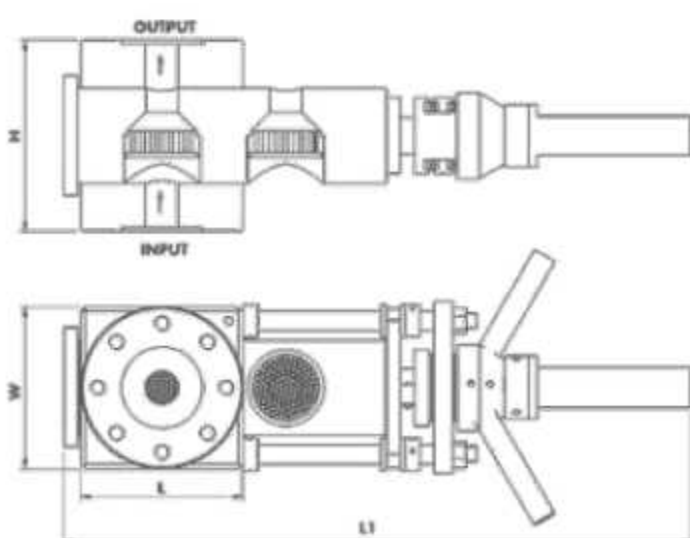

Applications

- Tape Plant
- Pipe Plant
- Lamination Plant
- Sheet Plant
- Film Plant
- Blown Film Plant
- Multilayer Blown Film Plant
- Co-extrusion Line
- Blow Moulding Extrusion Plant

Advantages:

- Filter remove the impurities and prevent the damages of Die.
- Filter improves the quality of final product.
- If it is Hydraulic operated so plant output will we increased compare to manual operating.
- Eliminate the idle time and easy to operate.
- Easy maintenance.
- Wear resistance proof.

SINGLE INJECTION MOULDING SCREW BARREL FOR RPVC,CPVC,UPVC



INJECTION HEAD & NOZZLE



RING PLUNGER SET



SINGLE SCREW & BARREL

TYPE - SINGLE

RANGE - ID 10 To 165 mm X LENGTH 400 To 4500 mm



INJECTION MOULDING SCREW BARREL



**HIGH
OUTPUT**

**INNOVATIVE
DESIGN**

**FAST
DELIVERY**

**BEST
QUALITY**

Single Thread of Screws

Screws are specially designed with different compression ratios for different end

Products :

1P.V.C. Film (Soft/Rigid/Shrink)
P.V.C. Profile (For Wood Pattern).
Compounds (All kinds of Compounds),
Injection Moulding Screws.

Maddoc Barrier Screws

Some of the raw materials need rigorous mixing, this screw is specially designed for such kind of materials

HDPE pipes, XLPE Cable,
Lay Flat Pipe, LLDPE Tubing,
PP Film, HM.

PRODUCTION PROCESS OF SCREW

Material Testing (EN-41 B Musco)
T-Condition (27 to 30 HRC)
Cutting of Screw
S.R. Process
Polishing
Grinding
Testing
Nitriding (65 to 68 HRC)
Regrinding
Polishing & Testing

PRODUCT PROCESS OF BARREL

Material Testing (EN-41 B Musco)
Boring
T - Condition (27 to 30 HRC)
Final Re Boring
Machining
Testing
Nitriding (65 to 68 HRC)
Grinding & Polishing



CONCEPT ENGINEERING

Add. : D-11/13/20, Adarsh Estate,
Part-2, Opp. Gurudwara, B/h. Ashish Manglam,
Adinath Road, Odhav, AHMEDABAD-382415
(Gujarat), INDIA.

Mob. : +91 99259 01300 (Bhavin Patel)
+91 99045 02640 (Sohil Patel)

E-mail : concept11engineering@gmail.com
concept11engineering@yahoo.com

Web : www.conceptenging.com

Screen Changer Inquiry : +91 9723213455 (Sagar Patel)